



# P-51D Mustang RTF Instruction Manual



ParkZone® products are distributed exclusively by  
Horizon Hobby, Inc.  
4105 Fieldstone Road  
Champaign, IL 61822  
© 2009 Horizon Hobby, Inc.

Horizon Hobby UK  
Units 1-4, Ployters Road  
Staple Tye  
Harlow, Essex  
CM18 7NS  
United Kingdom

Horizon Hobby Deutschland GmbH  
Hamburger Strasse 10  
25335 Elmshorn  
Germany

14597 Printed 4/09



**Charge-and-Fly™ Park Flyer**

Wingspan: 39.0 in (990mm)  
Length: 33.5 in (850mm)  
Weight: 25.0 oz (710 g)  
Motor: 480-size 960Kv brushless outrunner  
ESC: ParkZone 18A brushless  
FM Radio: ZX-10, 3 proportional channels 27MHz  
Battery: 3S 11.1V 1300mAh LiPo  
Charger: 3-cell LiPo balancing

## Introduction

Congratulations on your purchase of the ParkZone® P-51D Mustang. The North American P-51D Mustang is arguably the most famous military aircraft of all time. Many will credit the fall of the Nazi regime in Europe to the development and production of this great fighter. This was not only because they were able to protect long-range bombers such as the B-17, but because of their outstanding offensive capabilities.

Your P-51D Mustang RTF purchase includes everything needed to get you in the air—all in one box. You will only need to attach the wing, horizontal tail, and charge the battery pack prior to taking to the air. Everyone at ParkZone is committed to giving you the most enjoyable flight experience possible. In order for your first flight to be safe and successful, we ask that you do not fly until you have read these instructions thoroughly.

The P-51D Mustang comes with a fully proportional 3-channel FM radio system, with full control of throttle, ailerons, and elevator. If you are not experienced at flying one of HobbyZone's 3-channel aircraft, or any other 3-channel radio controlled aircraft, we recommend that you do not fly the P-51D Mustang. If you still choose to fly, you will need to seek the help of an experienced

radio control pilot during your first several flights. This is especially important if you have not flown a 3-channel airplane with aileron control as one of the channels. **Crash damage is not covered under the warranty.**

Your P-51D Mustang is equipped with the exclusive Mode Change Flight Control system. The computer onboard the airplane is programmed with two flight modes. You have two modes to choose from. One limits the travel of the ailerons and elevator to allow a better transition to flying with pitch control, as well as those experienced fliers looking for a smooth and relaxing flight. The second mode allows full control at all times for those that are experienced and looking for maximum performance.

Your P-51D Mustang is equipped with the exclusive ZX10 radio system which utilizes 10-bit, 1024-step processing for high-fidelity control. It uses a 6-channel FM receiver with industry standard 3-wire servos. The ZX10 system also features dual rates, allowing you to fly how you feel most comfortable. Mode A limits the travel of the control surfaces and offers smooth and relaxing flight. Mode B allows for full control at all times for those craving the maximum performance of their aircraft.

## RTF Components

- Transmitter
- Flight Battery
- Charger
- AA Batteries for Transmitter (8)
- Fuselage with Receiver, ESC, Motor, Propeller, Y-Harness and Servos Installed
- Wing with Aileron Servos Installed



## Step 1

### Setting Up the Transmitter

1. Insert 8 new AA batteries (supplied) into the transmitter, observing proper polarity.
2. Turn the switch on and check to make sure the LED is illuminated, which indicates that the batteries have been installed correctly. Once this is confirmed, turn the radio off.
3. You'll need to replace the transmitter AA batteries whenever you hear the low-battery alarm (beeping sound) being emitted from the transmitter. To extend the life of your AA batteries, remove them from your transmitter when it is not being used.

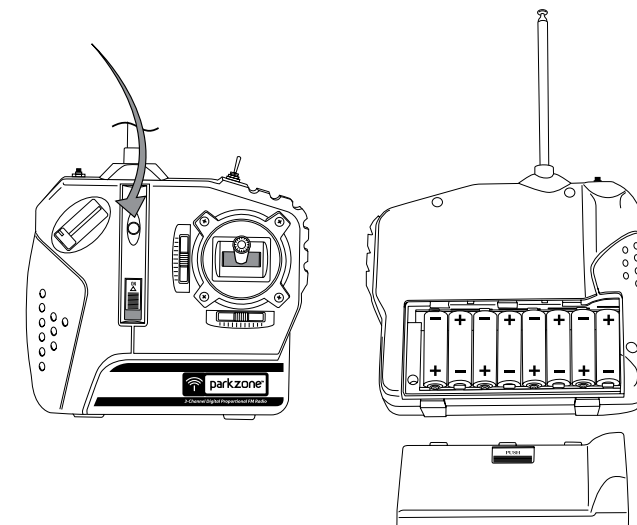

## Step 2

### Charging the Aircraft Battery

The charger included with your P-51D Mustang uses unique circuitry that ensures an accurate charge every time and protects your Lithium Polymer battery from the dangers of overcharging. This charger continually monitors the battery and automatically stops charging when the battery is fully charged.

#### DC Li-Po Balancing Charger Features

- Charges 3-cell lithium polymer battery packs at 1-amp
- LED charge status indicator
- 12V accessory outlet input cord—**you must charge the included Li-Po battery pack with a Li-Po specific charger only (such as the included charger). Never leave the battery and charger unattended during the charge process. Failure to follow the instructions properly could result in a fire. When charging, make certain the battery is on a heat-resistant surface.**

1. The 12V DC 3S Li-Po balancing charger provides a charge current of 1 amp. The typical charge time for the included 11.1V 1300mAh Li-Po is approximately 1 hour.
2. Locate the safety charge lead on the battery pack. Connect the battery pack to the charger. Charge through the balance lead on the battery pack. The blue EC3 connector will remain disconnected when using the included charger.

3. Connect the charger to a 12V power outlet in a vehicle or purchase the AC adapter (HBZ1004) to allow charging from a wall outlet. Please note that some 12V outlets require your vehicle to be running for the outlet to be operational. It is recommended to consult your vehicle owner's manual if you are unsure. The LED will continually blink while the battery charges. It is not recommended to charge batteries while the vehicle is in motion.

4. Charging is finished when the LED indicator glows steadily.

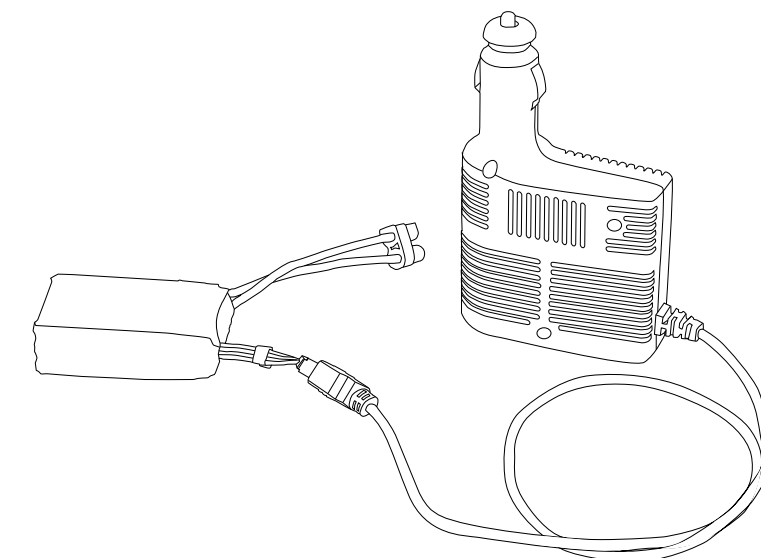

## Step 3

### Attaching the Wing

In order to attach the wing of your P-51D Mustang, please follow these simple instructions:

1. Locate the included wing screw (in clear plastic bag).
2. Plug in the aileron servo leads from the wing into the "Y" harness. Step 8 will guide you through the process of ensuring the ailerons are correct and not reversed.
3. Carefully attach the wing to the fuselage. The rear of the wing plugs into the fuselage and the front of the wing is secured with the wing screw.

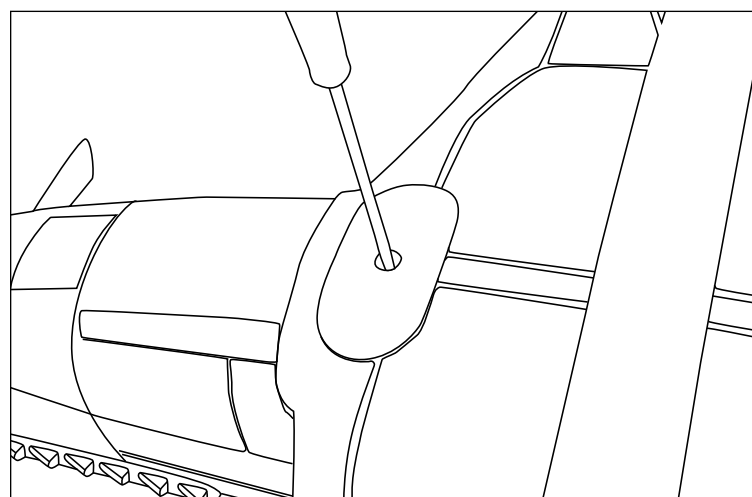
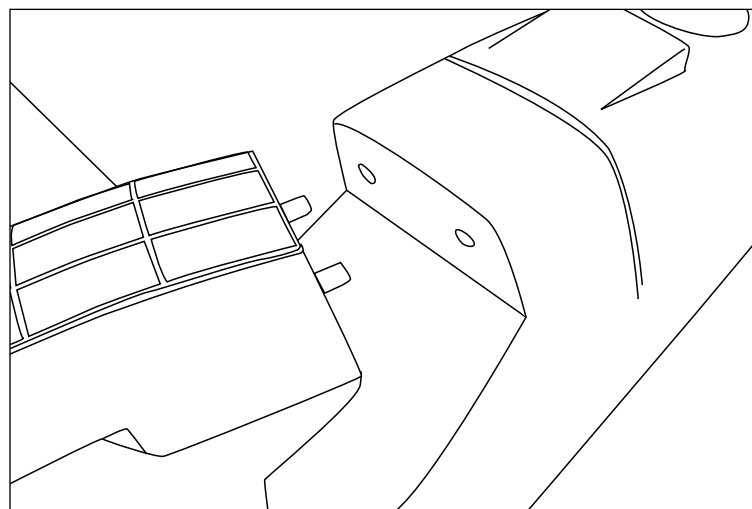

## Step 4

### Installing the Flight Battery

1. Place the battery in the battery compartment and secure in place with the hook and loop strap.
2. Plug the flight battery into the ESC with the blue EC3 connectors. **Do not plug balance lead of the battery into the receiver; this will damage the receiver and or battery.**

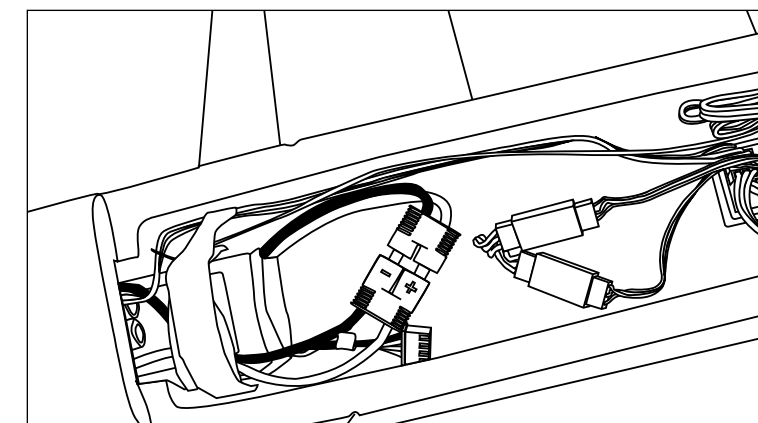
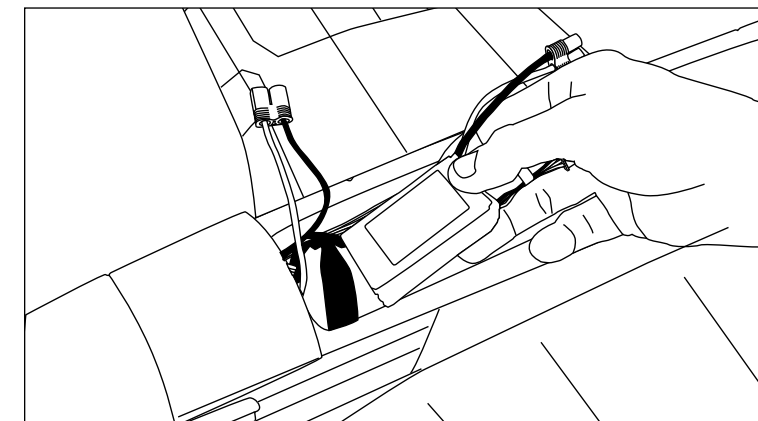

## Step 5

### Attaching the Horizontal Stabilizer

1. Locate the horizontal stab of the tail.
2. Slide the horizontal tail stab through the allotted space in the fuselage, making sure the control horn attached to the horizontal tail stab will properly align with the pushrod and clevis exiting the back of the fuselage.
3. When you are certain the tail is centered correctly, use the provided clear tape to properly secure the tail to the fuselage, as shown. Use the tape on the top and bottom of each side of the tail (total of 4 applications).
4. Make sure that the throttle slider is all the way down, in the "off" position. Turn on the transmitter and plug in the flight battery. Make sure the trim levers and control stick are centered.
5. Locate where the clevis and rod exit the fuselage, and attach the clevis to control surface as shown.
6. Make necessary trim adjustments prior to flight.

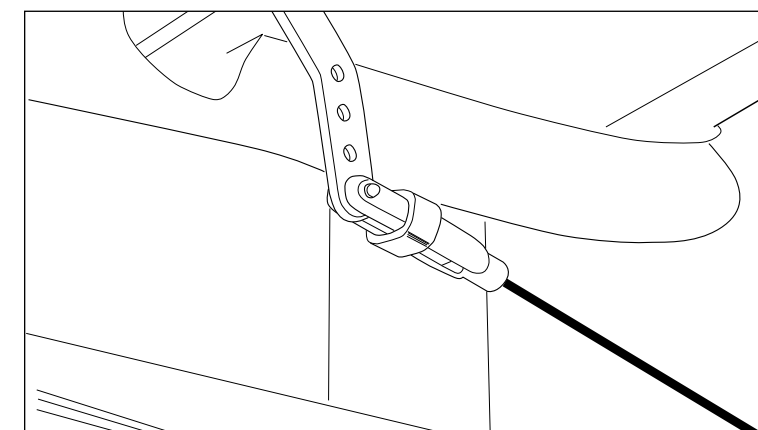
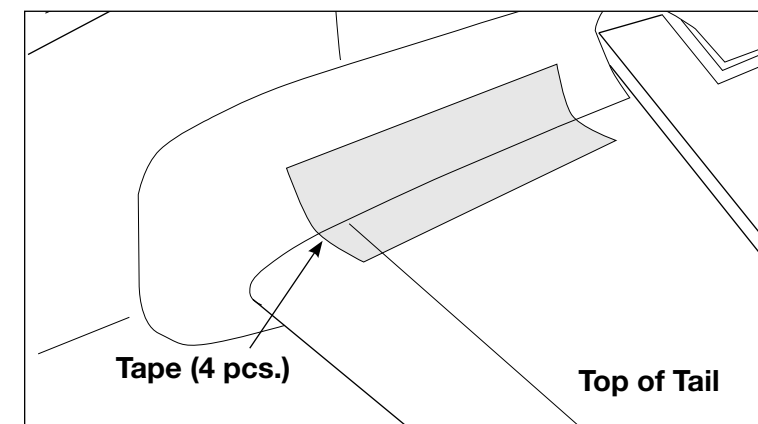

## Step 6

### Making Trim Adjustments to the Horizontal Stabilizer

1. Turn on the transmitter.
2. Install a fully charged battery into the battery compartment and secure it with the included hook and loop strap.
3. Set the elevator trim lever to center.
4. Make certain the elevator is set to neutral with the horizontal stabilizer. Do this by removing the clevis from the control horn and turning it on the pushrod as needed. Once the adjustment is made, reattach the clevis.
5. If you feel more adjustments are necessary while in flight, move the trim lever on the transmitter a few "clicks" up or down as needed.

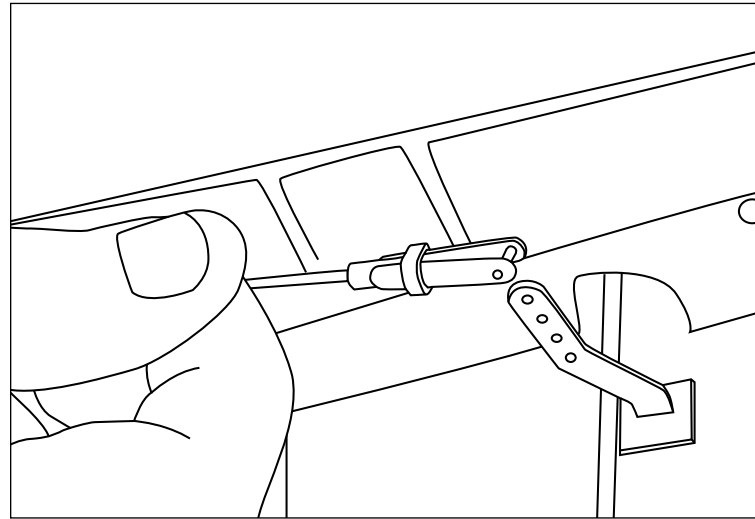

## Step 7

### Motor Test

**Warning:** Keep everything clear of the propeller before starting the motor test; so you do not damage any property or harm anyone.

1. Make sure the throttle slider is in the "off" position.
2. Turn on the transmitter.
3. Plug the flight battery into the lead inside the fuselage.
4. Secure the battery inside the fuselage cavity by looping the hook and loop straps around the battery.

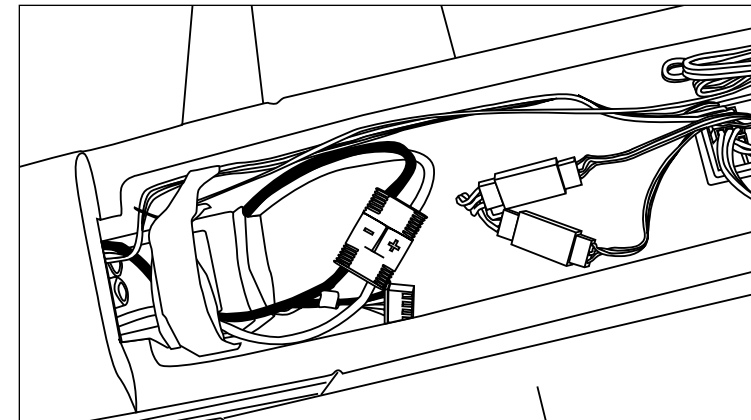
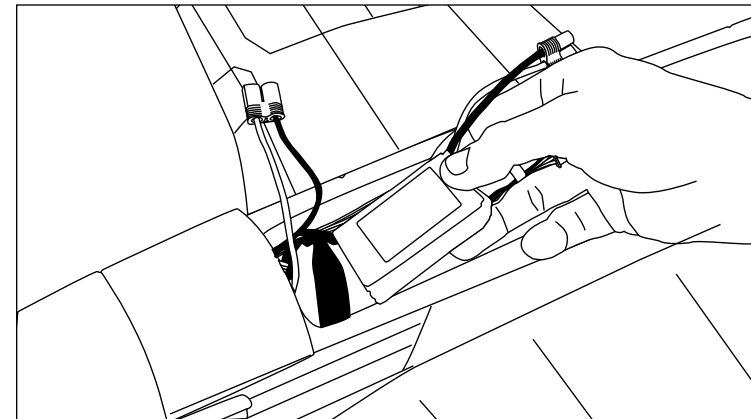

5. Your P-51D Mustang has a built-in throttle arming feature that must sense the throttle slider in the "off" position before it will spin the propeller. Advance the throttle forward and the propeller should spin at a high speed. The throttle slider needs to be in the "off" position each time the battery is plugged into the airplane.
6. **Follow this step each time you need to turn the airplane off.** When finished with the motor test, be sure to disconnect the battery first, and then turn off the transmitter. Each time you use your airplane you should always place the throttle in the "off" position, and then turn on the transmitter and plug the battery pack into the lead from the fuselage.
7. Make any trim adjustments, as necessary, prior to flight (see Making Trim Adjustments to the Horizontal Stabilizer and Making Adjustments to the Ailerons).

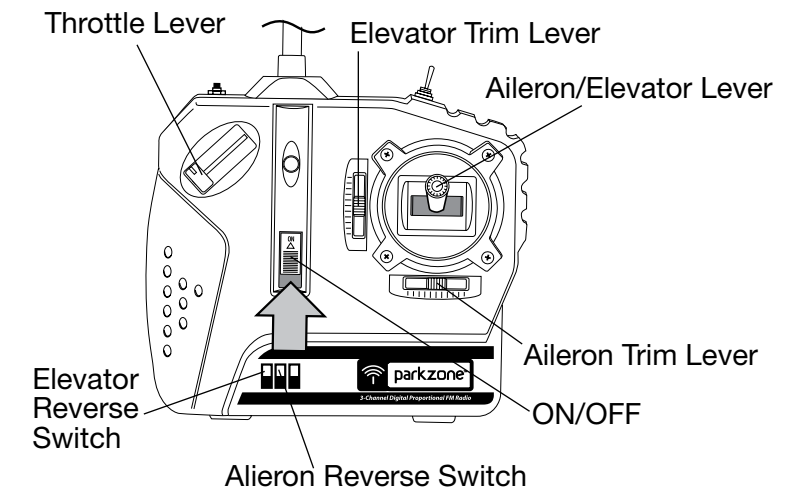

**Note:** Transmitter above reflects Mode 2 only

## Step 8

### Control Test

**Warning:** Keep everything clear of the propeller before starting the control test in the event that you accidentally turn on the motor.

1. Be certain that the throttle slider is in the "off" position and that both trim levers are centered.
2. Switch on the transmitter and check to make sure the LED is lit, indicating the transmitter has power.
3. Install the flight battery into the fuselage and plug it into the battery connector.
4. Move the stick from side to side. The ailerons on the trailing edge of the wings should move per your transmitter input. When the stick is pushed to the right, the right aileron should deflect upward and the left aileron downward, and vice versa.

**Note:** If ailerons or elevator are reversed simply move the reversing switch on the front face of the transmitter.

5. Pull the stick back and the elevator control surface should move upward (as shown).
6. Move the stick full forward. When this is done, the elevator control surface should move down (as shown).
7. When the test is complete, be sure to disconnect the flight battery first, and then turn off the transmitter. This should be done each time you turn off the airplane.

**Note:** It is very important to make sure that the control surfaces are at 0 degrees when the transmitter's control stick and trim levers are centered. (See Steps 5 and 8 for making needed adjustments to control surfaces.)

If your airplane is not responding correctly to the transmitter input, do not fly! Some correction is needed. Call the Horizon Support Team line at 1-877-504-0233.

**Note:** Transmitter below reflects Mode 2 only

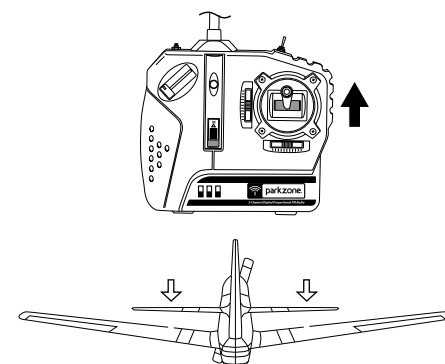
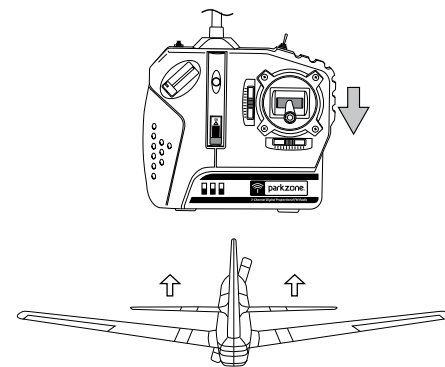
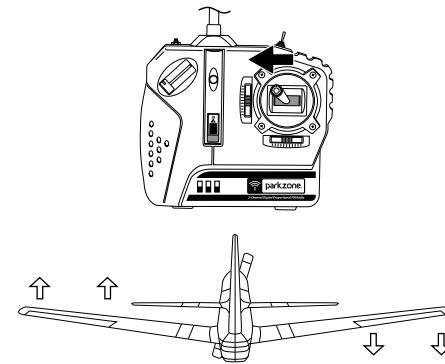
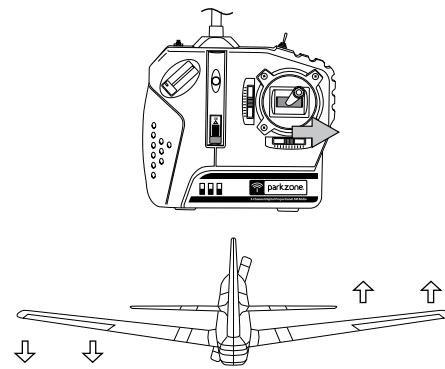

## Step 9

### Making Adjustments to the Ailerons

**Warning:** Keep everything clear of the propeller before adjusting the ailerons in the event that you accidentally turn on the motor.

You may find some adjustment is needed to properly trim the ailerons. The ailerons are properly trimmed when each aileron is level with the stationary wing surface. To do this, follow these simple instructions:

1. Make sure the throttle slider is in the "off" position and then turn on the transmitter.
2. Install the flight battery and plug it into the lead from the fuselage.
3. Most trim adjustments to the ailerons can be made with the aileron trim levers on the transmitter. Make sure the gimbal (stick) is at neutral prior to making any trim changes.

4. If trimming the ailerons with the trim levers is not sufficient, and the ailerons need to be trimmed mechanically, you'll need to do the following:
  - a. With the radio system on, return the trim levers and gimbal to their neutral positions.
  - b. Slide the silicone keeper back and open the clevis and remove the clevis from the aileron control horn.
  - c. Thread the clevis in or out to move the aileron to the neutral position.
  - d. Reattach the clevis to the aileron control horn and slide the silicone keeper back over the clevis to prevent the clevis from opening in flight.

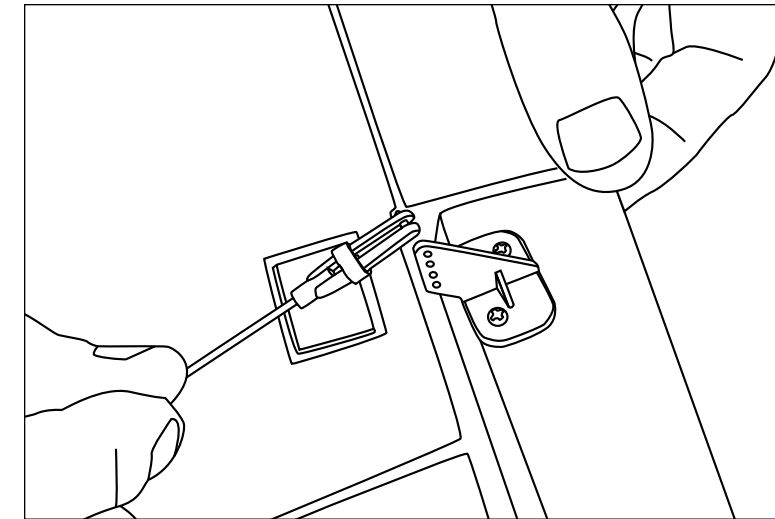

## Step 10

### Control throws and Center of Gravity

Control Throws:

	Low Rate	High Rate
Aileron:	1/4 inch (6.4mm)	3/8 inch (9.5mm)
Elevator:	1/4 inch (6.4mm)	3/8 inch (9.5mm)

Center of Gravity:

2 3/4 inches (70.0mm) From leading edge of the wing at the fuselage.

**Note:** The small oval panel line on the top of the wing marks the correct CG location.

## Step 11

### Choosing a Flying Field

- A large, open grassy field is required to fly your P-51D Mustang. Your P-51 can cover ground fast. The choice of a large field will ensure greater success for your flight.
- It is essential to have a minimum of 300 feet of clear space in all directions from the pilot.
- Make certain that you do not fly near trees, buildings, or other areas that can restrict your view or interfere with your flying. NEVER fly near streets, parking lots, or people.

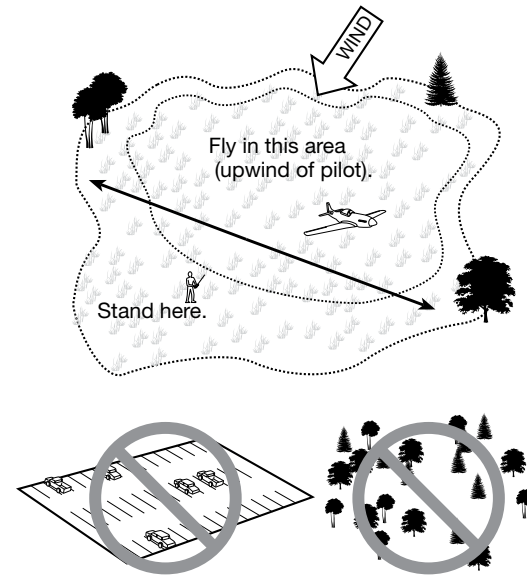

## Step 12

### Optimal Flying Conditions

You want to fly. However, you need to make sure that you fly in the conditions that will allow you to have the best success. This is when there is little to no wind (less than 8 mph or nearly 13 km/h).

### To check wind conditions:

1. Tie the included red ribbon to the transmitter antenna.
2. Hold the transmitter antenna so it is parallel to the ground and note how much the ribbon moves in the wind. If the ribbon hangs down, conditions are perfect to fly. There is some variance in the amount of wind that you can fly in, but if the angle between the antenna and the ribbon, when the antenna is parallel to the ground, is less than 20 degrees, it is too windy to fly.

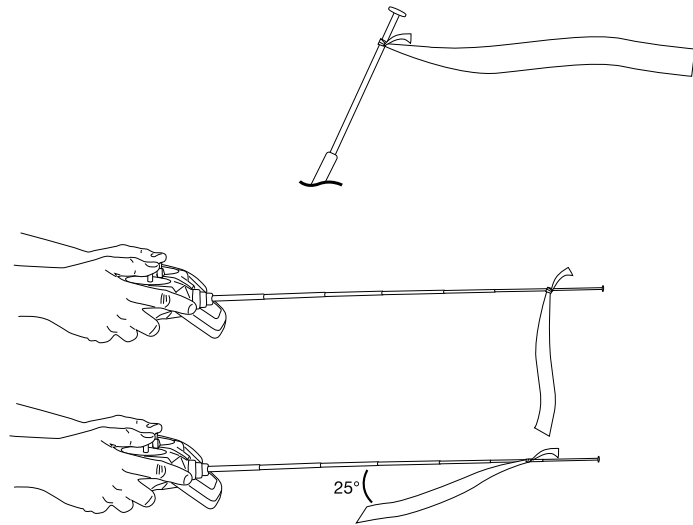

## Step 13

### Range Test

You will need two people to perform the range test—one to hold the plane and the other to give the transmitter input.

**Warning:** The person holding the plane should hold it in such a way that the propeller does not come into contact with any part of their clothing or body.

1. One person should hold the transmitter, while the other person walks 100 paces away from the transmitter, with the airplane in hand.
2. Be sure the throttle slider is in the “off” position.
3. Extend the transmitter antenna completely and turn the transmitter on.
4. Slide the battery into the fuselage, attach it to the lead from the fuselage and close the canopy.
5. Advance the throttle. When the throttle slider is advanced, the propeller should spin quickly.
6. As the first person moves the transmitter controls, the other person watches to be sure the airplane’s motor and tail controls operate smoothly. Make sure you check all parts of the controls—throttle, as well as moving the gimbal up and down, and side to side.

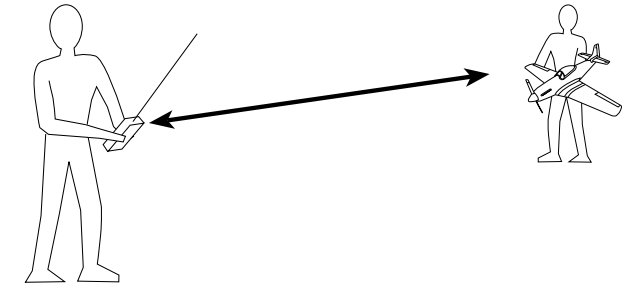

## Step 14

### First Flights

The ParkZone 3-channel control system is designed for the experienced radio control pilot and is not intended for the inexperienced flyer. If you have successfully flown 3-channel HobbyZone® airplanes, then you should be ready for the P-51D Mustang. However, first-time pilots of the P-51D Mustang should seek the assistance of an experienced RC flyer until the additional third channel, pitch control, has been competently mastered. If you do not have experience with controlling the ailerons, it will be very helpful to have an experienced pilot with you when you first start to fly. **Crash damage is not covered under the warranty.**

**Important:** Initial flights should always be done with the airplane in Low Rate (Mode A). In this mode, there is some limitation to the travel of the control surfaces, helping to prevent you from overcontrol. After you have had several safe flights in Mode A, you can move on to Mode B, which will no longer limit the travel of the control surfaces.

**Note:** It is possible to change flight modes while the plane is in flight. However, it is important that you have enough altitude while in flight before changing the flight mode.

## Step 15

### Mode Change Flight Control System

Your P-51D Mustang comes with the ability to change flight modes as you gain more experience and become more familiar with it. There are two modes, selectable from the transmitter, from which you can choose.

**Mode A (Low Rate)** - Mode A is recommended for all first flights. The travel of both ailerons, as well as the elevator, will be limited in this mode, allowing you to become more familiar with your plane. The switch on top of the transmitter will be back when you are in this mode.

**Mode B (High Rate)** - Mode B does not limit your control surface travel, allowing more aggressive flying and aerobatics. However, your P-51D Mustang will also be more prone to crashes due to over-control if you are not careful. The switch on the transmitter will be toward the pilot when in this mode.

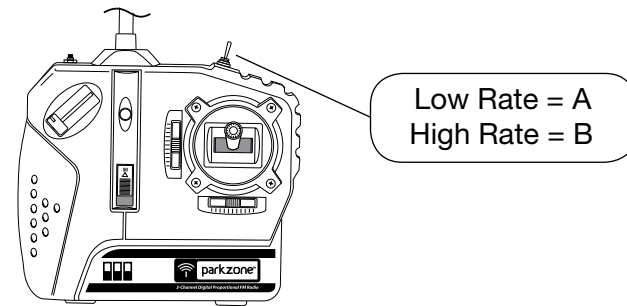

## Step 16

### Hand Launching the P-51 Mustang

Your P-51D Mustang will need to be hand launched. To do this, follow these instructions:

1. Make certain that the aircraft battery is fully charged.
2. Turn on the transmitter, making certain you are in Mode A (Low Rate).
3. Insert the battery into the fuselage and plug the battery lead into the lead coming from the fuselage. Secure the battery with the hook and loop straps.
4. Hold the airplane with your hand behind the wing gripping the fuselage.

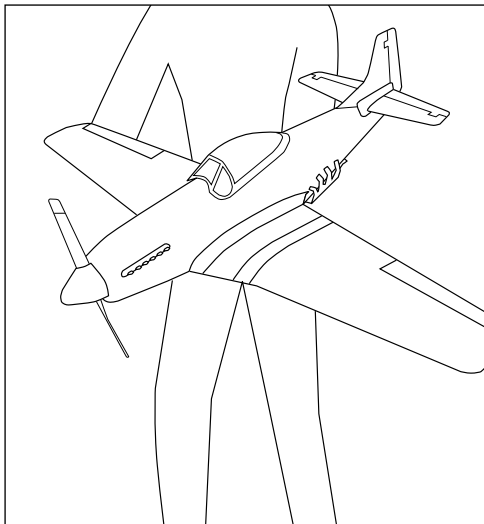

5. While holding the transmitter in one hand, push throttle slider to full on (up) with thumb.
6. Take a couple of steps and FIRMLY launch directly into the wind while keeping the wings level. Do not throw it up or down. Point it level (parallel) with the ground when launching. THROW IT HARD until you become accustomed to the amount of force it takes to launch the plane.
7. Keep steering into the wind and hold at full throttle in a slight climb until you have reached an altitude of at least 50 to 70 feet (15 to 21 meters).
8. When you have reached this altitude, it is safe to steer in the desired direction, as well as adjust the throttle input, to help control altitude and speed.

**Note:** If airplane is thrown too lightly it is possible that the airplane will not have enough airspeed to fly away and control authority will be reduced the slower it is thrown. The proper throw is similar to a javelin throw.

## Step 17

### Helpful Hints for Flight

1. After launching, your P-51D Mustang will climb at full throttle. Keep the throttle full on until you have reached an altitude of at least 50 feet (15 meters). At the same time, make sure that you continue to keep the airplane flying directly into the wind.
2. Make right and left adjustments, as necessary, to keep the plane headed directly into the wind. After you have reached approximately 100 feet (30 meters) of altitude, you can begin to make directional changes that you desire.
3. Remember—control range is 2,500 feet (762 meters). Do not allow the plane to get too far away from you. When the plane is farther away it is harder to see, and the higher you fly, the more the airplane will be affected by wind.
4. Always keep the plane upwind from you. This way, it will not be carried away from you by the wind.
5. Flying in winds that are too strong is by far the number one reason for those who are less experienced to crash or have flyaways.

6. Avoid holding the stick full right or left for more than two seconds, as this will cause the plane to enter a spiral dive that could cause you to crash your plane.
7. Do not try to climb too fast by pulling all the way back on the stick (up elevator), or your plane may stall. Instead, climb by giving small amounts of elevator.
8. **Damage/bends to the wings or tail can greatly affect flight control. Replace damaged parts immediately.**
9. Once you have become more experienced and familiar with the Mustang, you can switch from Mode A to Mode B. Mode B no longer limits the travel of the control surfaces.
10. Trees, buildings and obstructions can cause turbulence. Try to avoid launching or landing downwind of obstructions to minimize the effect of the turbulence.

# Warnings and Safety

1. Read and follow this manual completely, observing all instructions and safety directions. Otherwise, serious injury and damage can occur. Think about your safety, and the safety of others, first.
2. Keep the propeller away from body parts and clothing, even when it isn't spinning, as it could be turned on by accident. Beware of hair becoming entangled in the propeller, especially while launching your plane.
3. Do not fly when it's too windy or you may lose control and crash, causing injury or damage. Never fly near people, vehicles, train tracks, buildings, power lines, water, hard surfaces or trees. Never allow anyone to attempt to catch the airplane while it's in flight or serious injury may result.
4. **Age Recommendation: 14 years or over. This is not a toy. This product is not intended for use by children without direct adult supervision.**
5. Only use a battery charger that is Lithium Polymer compatible to charge the flight battery. Never leave the charger unattended while charging. This will help prevent overcharging and make sure damage does not occur to the battery, charger or any other property. While charging, place the battery on a heat-resistant surface. **Do not lay it on carpet or upholstery while charging.**
6. **Never cut into the battery, charger, or airplane wires or serious injury may occur.** Causing the battery to "short out" (crossing negative and positive bare wires) can cause fire, serious injury and damage.
7. Hold the plane securely when the flight battery is plugged in, and keep all body parts away from the propeller. When you finish flying your airplane, always unplug the battery before you turn off the transmitter.
8. Never fly on the same frequency as another RC vehicle in your area. The frequency of the airplane is shown on stickers on the back of the transmitter and on the airplane.

# Success Tips

1. Don't fly in winds over 10 mph! If you are a less experienced pilot, this is especially important.
2. A pilot who has never flown a 3-channel plane with pitch control should get help from an experienced radio control pilot during first flights. Pilots who have not flown a 3-channel plane at all should not fly unless an experienced RC pilot is present to guide them.
3. Choose your flying field carefully—grass and soft ground with a 600-foot (183-meter) diameter of open space is optimal for flying and will lengthen the life of your airplane. Make sure there are no obstacles that will get in your way when flying, such as trees or buildings. Make sure you do not fly where there are pedestrians who could be hurt by the airplane.
4. Remember that holding the stick full over for too long can cause the airplane to spiral dive and crash. At the very first sign of the plane beginning to spiral down, immediately release the stick and give the opposite turn control to the spiral, then pull back on the elevator gently to level flight and level the wings.
5. Don't attempt to fly or do maneuvers beyond your flying abilities. Seek the assistance of an experienced pilot when trying new maneuvers that are more extreme and involve fast flight.
6. If you're gliding with the motor off, allow your plane more area for turns.
7. Position yourself at your flying field so that you keep the sun at your back and out of your eyes. Wear sunglasses on bright days.
8. Keep the aircraft upwind, especially on windier days, to prevent it from "flying away." The wind is normally stronger at higher altitudes than it is on the ground.
9. Keep your plane in front of you so you don't have to turn in circles as you fly. Try to avoid flying directly overhead.

# Repairing Minor Damage

If you happen to crash, and part of the fuselage or wing breaks, you can repair the damage by using regular medium CA glue to glue the pieces back on, or packing tape to cover the missing pieces. However, if the damage is severe, or if the wings and/or tail, are bent, replace the damaged parts prior to flying again. See the last few pages of the manual for a complete list of replacement parts for your P-51D Mustang.

**Note: Horizontal stabilizer is not compatible with regular CA. Use foam-safe CA or replace stabilizer if damaged.**

# ParkZone 18-Amp ESC

## Specifications

Continuous Current: 18A\*  
Max Burst Current: 25A (15 sec)\*  
Length: 47.0mm  
Width: 27.5mm  
Height: 8.5mm  
Weight: 31.0 g  
Cells: 2-3S LiPo or 6-12 NiMH/NiCd  
Battery Input Leads: 16AWG with E-flite EC3 Connector  
Motor Output Leads: 16AWG with 3.5mm Female Gold Bullet Connectors

\* Proper cooling required

## Default Settings

9V Cutoff  
No Brake  
Motor Timing: 15 Degrees  
Throttle Input: 1.2–1.8ms

## Optional RS232 Serial Link & Programming Software

Programming your ESC will be much faster and easier when you purchase the optional RS232 Serial Link and programming software. This will allow you to update your ESC using a laptop or PC. You must have a Serial Port on your computer or you can purchase a separate USB to DB9 adapter (available at computer retailers).

EFLARS232—RS232 Serial Link/Programming Software

# Troubleshooting Guide

Motor and control surfaces do not respond	<ul style="list-style-type: none"> <li>• Transmitter AA batteries are depleted or installed incorrectly, indicated by a dim or unlit LED on the transmitter or the low battery alarm</li> <li>• No electrical connection</li> <li>• Flight battery not charged</li> <li>• Crash has damaged the radio inside the airplane</li> </ul>	<ul style="list-style-type: none"> <li>• Check polarity installation or replace with fresh AA batteries</li> <li>• Push connectors together until they are fully connected</li> <li>• Charge battery fully</li> <li>• Replace the fuselage or receiver</li> </ul>
Aircraft keeps turning on one direction	<ul style="list-style-type: none"> <li>• Aileron or aileron trim is not adjusted correctly</li> <li>• Damage to fixed rudder or vertical stabilizer</li> </ul>	<ul style="list-style-type: none"> <li>• Adjust aileron and/or aileron trim</li> <li>• Make sure fixed rudder/vertical stabilizer is at 90 degrees from elevator</li> </ul>
Aircraft is difficult to control after hard landing or crash	<ul style="list-style-type: none"> <li>• Wing or tail is damaged</li> </ul>	<ul style="list-style-type: none"> <li>• Replace damaged part</li> </ul>
Aircraft will not climb	<ul style="list-style-type: none"> <li>• Battery is not fully charged</li> <li>• Elevator trim may be incorrect</li> </ul>	<ul style="list-style-type: none"> <li>• Charge flight battery fully</li> <li>• Adjust elevator trim</li> </ul>
Aircraft keeps pitching up steeply	<ul style="list-style-type: none"> <li>• Wind is too gusty or strong</li> <li>• Battery may have slid out of the battery cavity</li> <li>• Elevator trim may have been raised too much</li> </ul>	<ul style="list-style-type: none"> <li>• Postpone flying until the wind calms down</li> <li>• Refer to Step 9 for CG information and make sure battery is securely strapped into the battery cavity</li> <li>• Trim elevator down with the transmitter trim or threaded linkage</li> </ul>
Control surface does not function	<ul style="list-style-type: none"> <li>• Servo plugged in backwards</li> <li>• Servo burned out</li> <li>• Servo could have stripped gears</li> </ul>	<ul style="list-style-type: none"> <li>• Reverse direction of servo lead into receiver</li> <li>• Replace servo</li> <li>• Replace servo</li> </ul>
Airplane has a vibration	<ul style="list-style-type: none"> <li>• Motor shaft bent</li> <li>• Firewall may be loose from hard landing</li> <li>• Damage to propeller or spinner</li> </ul>	<ul style="list-style-type: none"> <li>• Replace motor shaft</li> <li>• Re-secure with epoxy</li> <li>• Replace propeller HBZ1002, or replace spinner PKZ1807</li> </ul>
Aircraft appears to show significant decrease in flight time	<ul style="list-style-type: none"> <li>• Flight battery is not fully charged</li> <li>• PKZ1033 battery has been over-discharged multiple times, causing damage to battery life</li> </ul>	<ul style="list-style-type: none"> <li>• Recharge flight battery completely</li> <li>• Replace PKZ1033 battery</li> </ul>

# Replacement and Optional Parts

## Replacement Parts

PKZ1033	11.1V 1300mAh Li-Po Battery with EC3 Connector
PKZ1080	SV80 Short Lead 3-Wire Servo
PKZ1019	Propeller 9 x 6: P-51 BL
PKZ1020	Prop Adapter: P-51 BL
PKZ1771	Tx: CH 1, 26.995:
PKZ1772	Tx: CH 2, 27.045:
PKZ1773	Tx: CH 3, 27.095:
PKZ1774	Tx: CH 4, 27.145:
PKZ1775	Tx: CH 5, 27.195:
PKZ1776	Tx: CH 6, 27.255:
PKZ1802	Decal Sheet: P-51D BL
PKZ1807	Spinner: P-51D BL
PKZ1813	Clear Canopy and Painted Hatch: P-51D BL
PKZ1814	18A Brushless ESC
PKZ1820	Bare Wing (Painted, No Decals or Servos): P-51D BL
PKZ1822	Pushrods with Clevis: P-51D BL
PKZ1823	Control Horn set
PKZ1824	Horizontal Stabilizer with Accessories: P-51D BL
PKZ1825	Motor Mount: P-51D BL
PKZ1826	Cowl with Exhaust: P-51D BL
PKZ1867	Bare Fuselage (Painted, No Decals): P-51D BL
PKZ1870	Replacement Airframe: P-51 BL
PKZ4416	480 Brushless Outrunner Motor, 960Kv
PKZ4418	Motor shaft: 480 Outrunner
PKZ4551	Rx: CH 1, 26.995:
PKZ4552	Rx: CH 2, 27.045:
PKZ4553	Rx: CH 3, 27.095:
PKZ4554	Rx: CH 4, 27.145:
PKZ4555	Rx: CH 5, 27.195:
PKZ4556	Rx: CH 6, 27.255:
HBZ1003	DC Li-Po Balancing Charger

## Optional Parts

HBZ1004	1.5A AC Power Supply
---------	----------------------

# Warranty

## Warranty Period

Exclusive Warranty- Horizon Hobby, Inc., (Horizon) warranties that the Products purchased (the “Product”) will be free from defects in materials and workmanship at the date of purchase by the Purchaser.

## Limited Warranty

(a) This warranty is limited to the original Purchaser (“Purchaser”) and is not transferable. REPAIR OR REPLACEMENT AS PROVIDED UNDER THIS WARRANTY IS THE EXCLUSIVE REMEDY OF THE PURCHASER. This warranty covers only those Products purchased from an authorized Horizon dealer. Third party transactions are not covered by this warranty. Proof of purchase is required for warranty claims. Further, Horizon reserves the right to change or modify this warranty without notice and disclaims all other warranties, express or implied.

(b) Limitations- HORIZON MAKES NO WARRANTY OR REPRESENTATION, EXPRESS OR IMPLIED, ABOUT NON-INFRINGEMENT, MERCHANTABILITY OR FITNESS FOR A PARTICULAR PURPOSE OF THE PRODUCT. THE PURCHASER ACKNOWLEDGES THAT THEY ALONE HAVE DETERMINED THAT THE PRODUCT WILL SUITABLY MEET THE REQUIREMENTS OF THE PURCHASER’S INTENDED USE.

(c) Purchaser Remedy- Horizon’s sole obligation hereunder shall be that Horizon will, at its option, (i) repair or (ii) replace, any Product determined by Horizon to be defective. In the event of a defect, these are the Purchaser’s exclusive remedies. Horizon reserves the right to inspect any and all equipment involved in a warranty claim. Repair or replacement decisions are at the sole discretion of Horizon. This warranty does not cover cosmetic damage or damage due to acts of God, accident, misuse, abuse, negligence, commercial use, or modification of or to any part of the Product. This warranty does not cover damage due to improper installation, operation, maintenance, or attempted repair by anyone other than Horizon. Return of any goods by Purchaser must be approved in writing by Horizon before shipment.

## Damage Limits

HORIZON SHALL NOT BE LIABLE FOR SPECIAL, INDIRECT OR CONSEQUENTIAL DAMAGES, LOSS OF PROFITS OR PRODUCTION OR COMMERCIAL LOSS IN ANY WAY CONNECTED WITH THE PRODUCT, WHETHER SUCH CLAIM IS BASED IN CONTRACT, WARRANTY, NEGLIGENCE, OR STRICT LIABILITY. Further, in no event shall the liability of Horizon exceed the individual price of the Product on which liability is asserted. As Horizon has no control over use, setup, final assembly, modification or misuse, no liability shall be

assumed nor accepted for any resulting damage or injury. By the act of use, setup or assembly, the user accepts all resulting liability.

If you as the Purchaser or user are not prepared to accept the liability associated with the use of this Product, you are advised to return this Product immediately in new and unused condition to the place of purchase.

Law: These Terms are governed by Illinois law (without regard to conflict of law principals).

## Safety Precautions

This is a sophisticated hobby Product and not a toy. It must be operated with caution and common sense and requires some basic mechanical ability. Failure to operate this Product in a safe and responsible manner could result in injury or damage to the Product or other property. This Product is not intended for use by children without direct adult supervision. The Product manual contains instructions for safety, operation and maintenance. It is essential to read and follow all the instructions and warnings in the manual, prior to assembly, setup or use, in order to operate correctly and avoid damage or injury.

## Questions, Assistance, and Repairs

Your local hobby store and/or place of purchase cannot provide warranty support or repair. Once assembly, setup or use of the Product has been started, you must contact Horizon directly. This will enable Horizon to better answer your questions and service you in the event that you may need any assistance. For questions or assistance, please direct your email to [productsupport@horizonhobby.com](mailto:productsupport@horizonhobby.com), or call 877.504.0233 toll free to speak to a service technician.

## Inspection or Repairs

If this Product needs to be inspected or repaired, please call for a Return Merchandise Authorization (RMA). Pack the Product securely using a shipping carton. Please note that original boxes may be included, but are not designed to withstand the rigors of shipping without additional protection. Ship via a carrier that provides tracking and insurance for lost or damaged parcels, as Horizon is not responsible for merchandise until it arrives and is accepted at our facility. A Service Repair Request is available at [www.horizonhobby.com](http://www.horizonhobby.com) on the “Support” tab. If you do not have internet access, please include a letter with your complete name, street address, email address and phone number where you can be reached during business days, your RMA number, a list of the included items, method of payment for any non-warranty expenses and a brief summary of the problem. Your

original sales receipt must also be included for warranty consideration. Be sure your name, address, and RMA number are clearly written on the outside of the shipping carton.

## Warranty Inspection and Repairs

To receive warranty service, you must include your original sales receipt verifying the proof-of-purchase date. Provided warranty conditions have been met, your Product will be repaired or replaced free of charge. Repair or replacement decisions are at the sole discretion of Horizon Hobby.

## Non-Warranty Repairs

Should your repair not be covered by warranty the repair will be completed and payment will be required without notification or estimate of the expense unless the expense exceeds 50% of the retail purchase cost. By submitting the item for repair you are agreeing to payment of the repair without notification. Repair estimates are available upon request. You must include this request with your repair. Non-warranty repair estimates will be billed a minimum of ½ hour of labor. In addition you will be billed for return freight. Please advise us of your preferred method of payment. Horizon accepts money orders and cashiers checks, as well as Visa, MasterCard, American Express, and Discover cards. If you choose to pay by credit card, please include your credit card number and expiration date. Any repair left unpaid or unclaimed after 90 days will be considered abandoned and will be disposed of accordingly. Please note: non-warranty repair is only available on electronics and model engines.

## United States:

Electronics and engines requiring inspection or repair should be shipped to the following address:

Horizon Service Center  
4105 Fieldstone Road  
Champaign, Illinois 61822

All other Products requiring warranty inspection or repair should be shipped to the following address:

Horizon Product Support  
4105 Fieldstone Road  
Champaign, Illinois 61822

Please call 877-504-0233 or e-mail us at [productsupport@horizonhobby.com](mailto:productsupport@horizonhobby.com) with any questions or concerns regarding this product or warranty.

## United Kingdom:

Electronics and engines requiring inspection or repair should be shipped to the following address:

Horizon Hobby UK  
Units 1-4 Ployters Rd  
Staple Tye  
Harlow, Essex  
CM18 7NS  
United Kingdom

Please call +44 (0) 1279 641 097 or e-mail us at [sales@horizonhobby.co.uk](mailto:sales@horizonhobby.co.uk) with any questions or concerns regarding this product or warranty.

## Germany:

Electronics and engines requiring inspection or repair should be shipped to the following address:

Horizon Technischer Service  
Hamburger Strasse 10  
25335 Elmshorn  
Germany

Please call +49 4121 46199 66 or e-mail us at [service@horizonhobby.de](mailto:service@horizonhobby.de) with any questions or concerns regarding this product or warranty.

# CE Compliance Information for the European Union

 **Instructions for Disposal of WEEE by Users in the European Union**  
This product must not be disposed of with other waste. Instead, it is the user's responsibility to dispose of their waste equipment by handing it over to a designated collection point for the recycling of waste electrical and electronic equipment. The separate collection and recycling of your waste equipment at the time of disposal will help to conserve natural resources and ensure that it is recycled in a manner that protects human health and the environment. For more information about where you can drop off your waste equipment for recycling, please contact your local city office, your household waste disposal service or where you purchased the product.

**Declaration of Conformity**  
(in accordance with ISO/IEC 17050-1)

No. HH2009051301

Product(s): ParkZone P-51 BL RTF  
Item Number(s): PKZ1800  
Equipment class: 1

The objects of declaration described above are in conformity with the requirements of the specifications listed below, following the provisions of the European R&TTE directive 1999/5/EC:

- EN 300-220** Technical requirements for Radio equipment
- EN 301 489-1, 301 489-3** General EMC requirements for Radio equipment

Signed for and on behalf of:  
Horizon Hobby, Inc.  
Champaign, IL USA  
May 13, 2009

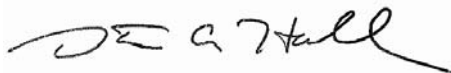
  
Steven A. Hall  
Vice President  
International Operations and Risk  
Management  
Horizon Hobby, Inc.

