

# Micro Troop Transporter

INFRARED R/C HELICOPTER

## PRECAUCIÓN: FUNCIONA CON ELECTRICIDAD.

No recomendado para niños menores de 14 años. Al funcionar con electricidad, deben cumplirse los consejos de seguridad durante la manipulación y la utilización para evitar posibles descargas eléctricas. Se requiere la supervisión del adulto.

## CAUTION: ELECTRIC TOY.

Not recommended for children under 14 years of age. As with all electric products, precautions should be observed during handling and use to prevent electric shock. Adult supervision is required.

 **WARNING**  
CHOKING HAZARD - SMALL PARTS  
NOT FOR CHILDREN UNDER 3 YEARS

**14+**  
yrs

  
**venom**  
[WWW.VENOM-GROUP.COM](http://WWW.VENOM-GROUP.COM)  
[WWW.VENOM-GROUP.COM](http://WWW.VENOM-GROUP.COM)

VENF-6242-1  
04-09

Thank you \_\_\_\_\_

Thank you for purchasing the Venom Micro Troop Transporter. This Ready to Fly (RTF) helicopter is perfect for taking on missions in your living room from the coffee table base to the sofa mountain range. With dual counter rotating blades, you will be able to easily navigate through tight living room canyons. A fully charged Micro Troop Transporter will fly for 7-10 minutes.

Index \_\_\_\_\_

|                                    |       |
|------------------------------------|-------|
| Intro .....                        | Pg. 1 |
| Battery Installation .....         | Pg.1  |
| Charging Instruction .....         | Pg.2  |
| Transmitter & Helicopter Key ..... | Pg.2  |
| Flying Instructions .....          | Pg.3  |
| Trimming Instructions .....        | Pg.4  |
| Replacement Parts List .....       | Pg.5  |
| Warnings and Cautions .....        | Pg.6  |
| Venom Guarantee .....              | Pg.6  |

Battery Installation \_\_\_\_\_

- 1) Remove cover using a Phillips head screw driver.
  - 2) Insert 6 AA Alkaline Batteries into the tray provided.
- NOTE: Make sure the battery polarity is correct.**



## Charging Instructions

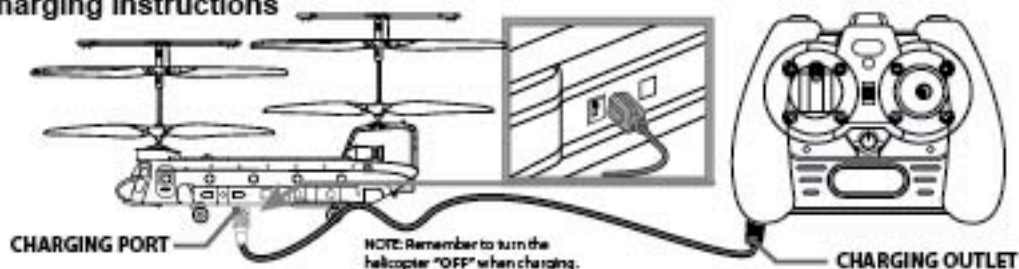

1. Plug the charger into an open wall outlet.
2. Make sure the helicopter ON/OFF switch is in the "OFF" position then insert the charging plug into the charging port on the bottom of the helicopter. When the light on the charger is RED this means the helicopter needs to be charged. When the light changes to green the helicopter has been fully charged. The Venom™ Micro Troop Transporter is now ready to fly.

**NOTE:** Charge times will vary depending on the amount of charge still left on the battery from previous flights. A fully discharged battery should take approximately 20-30 minutes to fully charge.

When the helicopter will no longer maintain a hover or gain altitude, the battery needs to be recharged. **DO NOT CONTINUE TO FLY THE HELICOPTER AS THIS MAY DAMAGE THE BATTERY!**

## Transmitter and Helicopter Key

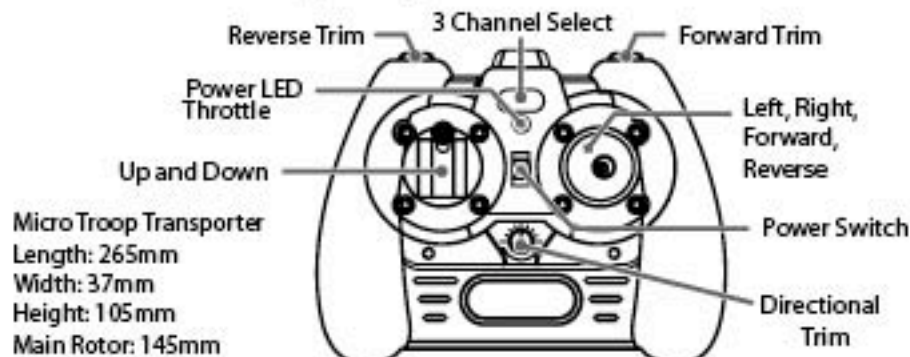

Micro Troop Transporter  
Length: 265mm  
Width: 37mm  
Height: 105mm  
Main Rotor: 145mm

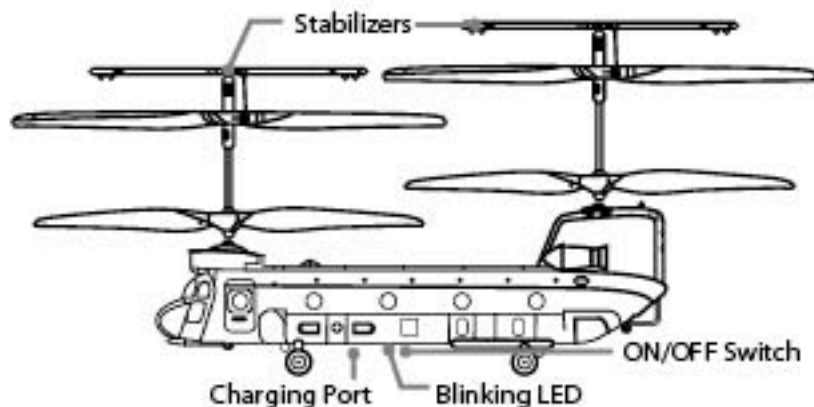

## Flying Instructions



To get the Micro Troop Transporter up, move the left control stick to the up position. Make sure to bring the control stick back down when the desired height is reached

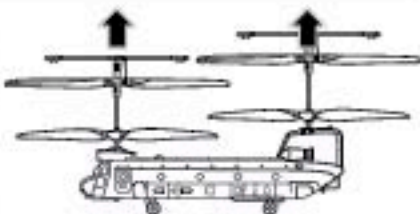

To lower your helicopter back down to the floor. Slowly move the left control stick down. The slower the input the less chance you have of crashing the helicopter.

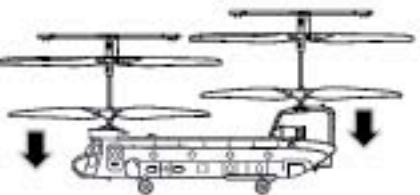

To move your helicopter forward move the right control stick up with the left control stick up or at the desired throttle level.



To move your helicopter in reverse move the right control stick down with the left control stick up or at the desired throttle level.

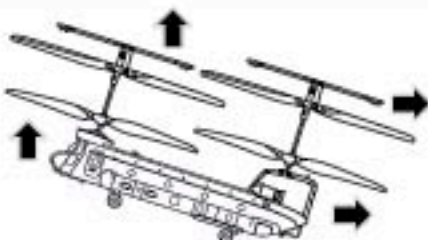

## Adjusting the Forward & Reverse Trim

If your Micro Troop Transporter moves forward, reverse, up or down without any input from the transmitter, the helicopter will need to be trimmed using the Reverse Trim, Forward Trim, or Directional Trim. To balance the helicopter in flight please refer to drawing below.

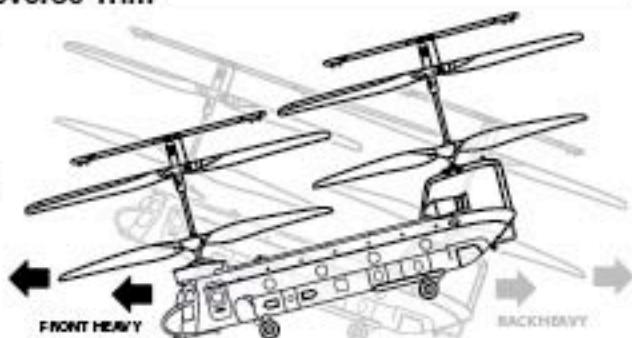

### REVERSE TRIM

If your helicopter is **FRONT HEAVY** and moves in a forward motion without any input from the transmitter, click the **REVERSE TRIM** until the helicopter becomes level with the floor.



### FORWARD TRIM

If your helicopter is **BACK HEAVY** and moves in a reverse motion without any input from the transmitter, click the **FORWARD TRIM** until the helicopter becomes level with the floor.

## Adjusting the Left & Right Trim

### RIGHT SPIN



If your helicopter rotates to the **RIGHT** without any sort of input from the transmitter, turn the **DIRECTIONAL TRIM** to the **LEFT** to stop the helicopter from spinning to the right.

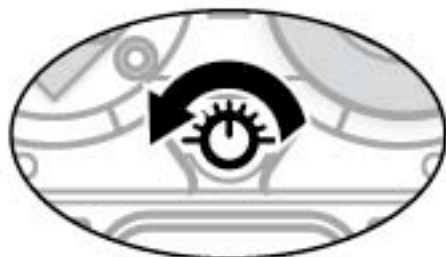

DIRECTIONAL TRIM

### LEFT SPIN



If your helicopter rotates to the **LEFT** without any sort of input from the transmitter, turn the **DIRECTIONAL TRIM** to the **RIGHT** to stop the helicopter from spinning to the left.



DIRECTIONAL TRIM

## Replacement Parts



VENF-7930  
Upper Main  
Blade Grip Set



VENF-7931  
Lower Main  
Blade Grip Set



VENF-7932  
Blade Set



VENF-7933  
Fly Bar

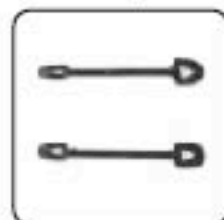

VENF-7934  
Control Links



VENF-7935  
Inner Shaft



VENF-7936  
Shaft with Gear



VENF-7937  
Main Gear

## Replacement Part Guide

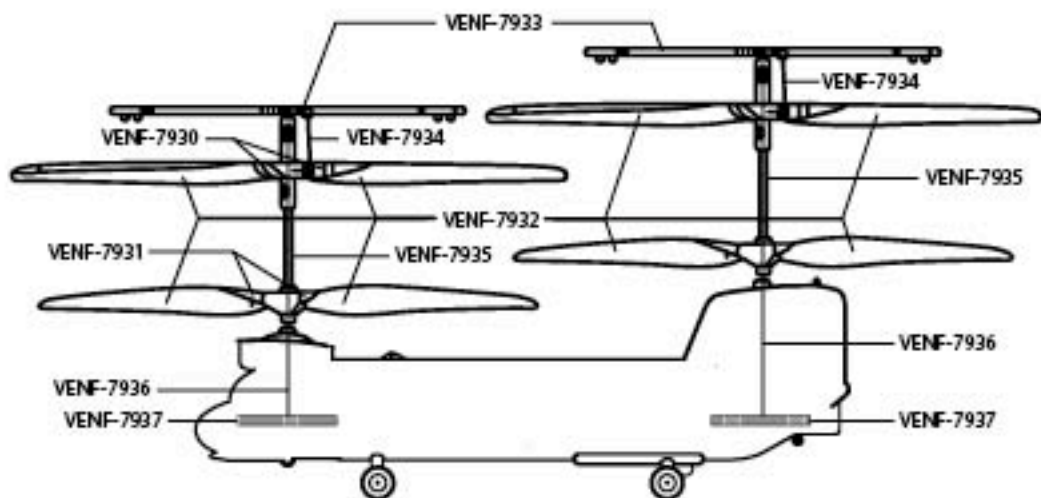

## Warnings & Cautions

---

### WARNINGS:

- When Charging the Micro Troop Transporter, always remember to turn the helicopter to the "OFF" position.
- When Flying the helicopter indoors, make sure you have a clear area of 20ft (Wide) x 30ft (Length) x 10ft (Height).
- Keep clear of the following objects: electric and overhead fans, air-conditioners, reading lamps and/or other dangerous objects.
- Operating the Infrared transmitter under direct sunlight or bright light may disrupt the signal to the helicopter.
- DO NOT COVER THE INFRARED SIGNAL with tape, stickers, or hand, this may interrupt the signal to the helicopter.
- DO NOT COVER THE HELICOPTER RECEIVER with tape, stickers, this may interrupt the signal as well.
- When flying the helicopter outside make sure wind conditions are calm.
- When flying outside also make sure of traffic, overhead electric lines or other dangerous objects.

### CAUTION:

- Remove old batteries and replace with new batteries. Be sure to insert batteries correctly according to (+) and (-) symbols located in the battery compartment.
- Be sure to insert batteries correctly with adult supervision and always follow the toy and battery manufacturer's instructions.
- Do not mix old and new batteries.
- Do not mix alkaline, standard (carbon-zinc), or rechargeable batteries.
- Rechargeable batteries are to be removed from the transmitter before being charged.
- Non-rechargeable batteries are not to be recharged.
- Rechargeable batteries are only to be charged under Adult Supervision.
- Only batteries of the same or equivalent type as recommended are to be used.
- Always remove weak or dead batteries from the product.
- Remove batteries if the product will be stored for an extended period of time.
- This product's battery is NOT replaceable

### Venom™ Limited Warranty

---

Venom™ warrants this product to be free of material and workmanship defects when new. If a component is defective or was not correctly made, Venom™ will, at its sole discretion, repair or replace it free of charge within 90 days from date of purchase. If you believe a defect became evident only after operation, please contact us to discuss the situation.

A dated & itemized sales receipt must accompany any product returned for warranty work. Before returning any product, please contact Venom™ Customer Service at 800-705-0620 to receive a Return Merchandise Authorization Number (RMA#).

### GUARANTEE:

---

We guarantee this product to be free of manufacturing faults and material defects. This product has been checked and adjusted individually before leaving the manufacturer. Please contact your local hobby shop for replacement parts and technical support or contact Venom™ Customer Service at 800.705.0620 or [customerservice@venom-group.com](mailto:customerservice@venom-group.com).

Charging and discharging batteries has the potential for serious injury to persons and damage to property. In purchasing this product, the user agrees to accept responsibility for all such risks, and will not hold Venom™, its affiliates, manufacturers, distributors, or retail partners responsible for any accident, injury to persons, or damage to property resulting from the use of this product.

This product contains chemicals known to the State of California to cause Cancer, Birth Defects and other Reproductive Harm. Be responsible, dispose of properly.

Adult supervision is required when using this product. This product should be assembled by an adult before use. Proper assembly should be checked by an adult before use. This product should be periodically examined by an adult for potential hazards. Any potential hazardous parts should be repaired or replaced.

#### Notice of Rights

All rights reserved. No part of these instructions may be reproduced or transmitted in any form by any means, electronic, mechanical, photocopying, recording, or otherwise, without the prior written permission of Venom™. For information on getting permission for reprints and excerpts, contact [customerservice@venom-group.com](mailto:customerservice@venom-group.com).

#### Notice of Liability

The information in these instructions is distributed on an "As Is" basis, without warranty. While every precaution has been taken in the preparation of these instructions Venom™ does not have any liability to any person or entity with respect to any loss or damage caused or alleged to be caused directly or indirectly by the information contained in these instructions or by the products described in it.



Venom Group International  
600 West Buddies Rd.  
Hayden, ID 83835

Australia  
PO Box 7305  
Alexandria NSW 2015

Customer Service  
800.705.0630  
[customerservice@venom-group.com](mailto:customerservice@venom-group.com)

© Copyright 2009 by Venom™

VENF-6242-1  
04-09